

HRA

series



Pressure Reducing Angle Valve

- Applicative units for: Used With A Fire Hose Rack Assembly.
- Working Pressure: 175 PSI (12.06 bar)
- Working Temp.: -10°C to 80°C (14°F to 176°F)
- Connection: HRA-175: NPT inlet (F) x NPT outlet (F)
HRA-175S: NPT inlet (F) x NST outlet (M)
- Water Pressure Is Controlled By Adjustable Flow Restriction.
- Locking Pin Device Restricts Full Opening Of Valve By Untrained Personnel.



**HRA-175
HRA-175S**

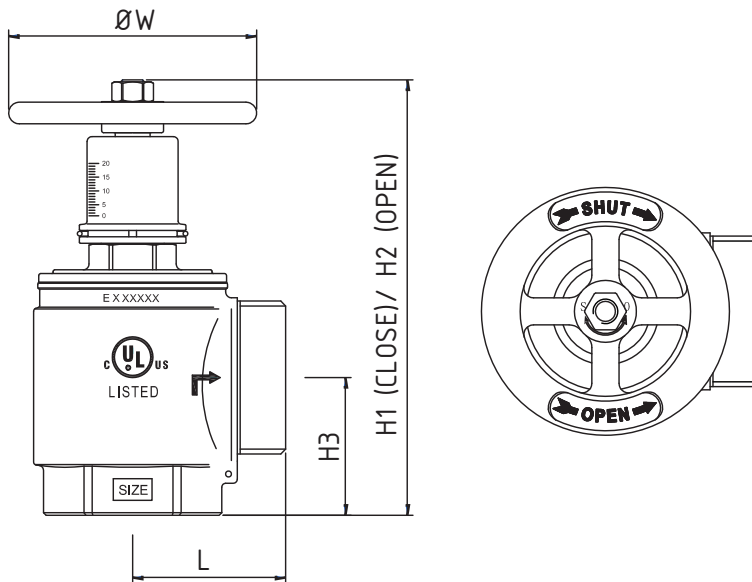

ITEM	PARTS	MATERIAL
1	BODY	BRASS
2	SEAT	NBR
3	BONNET	BRASS
4	INSTRUMENT	BRASS
5	STEM	BRASS
6	DISC HOLDER	BRASS
7	CLAMPING RING	BRASS
8	O-RING	NBR
9	NUT	SS
10	INDICATOR	BRASS
11	NAME PLATE	ALUMINUM

SIZES		DIMENSIONS (MM)					
Inch	mm	L1	H2	H3	L	ØW	CONNECTION
1-1/2"	DN 40	162.5	189	50	58.1	90	NPT inlet (F) x NPT outlet (F)
2-1/2"	DN 65	221	271	70	79	127	NPT inlet (F) x NPT outlet (F)
1-1/2"	DN 40	162.5	189	50	58.1	90	NPT inlet (F) x NST outlet (M)
2-1/2"	DN 65	221	271	70	79	127	NPT inlet (F) x NST outlet (M)